

18C 4013

VW T6, Md. 2015

EU-pedestrian protection bar 60 mm with cross pipe 42 mm

EU-Personenschutzbügel 60 mm mit Querrohr 42 mm

Protection avant, homologuée CEE, 60 mm, traverse 42 mm



*Compatible with Automatic Cruise Control /Forward Collision Mitigation
Kompatibel mit Abstandsregeltempomat /Auffahrvermeidungs-oder warnsystem
compatible avec radar de régulation de distance/ freinage autonome d'urgence

ASSEMBLY INSTRUCTION

Montageanleitung • Instructions de montage

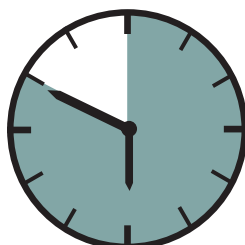

50 Minuten

article no.:

18C4013 (S) inox

18C5013 black steel

Revision 4: 03.09.2019



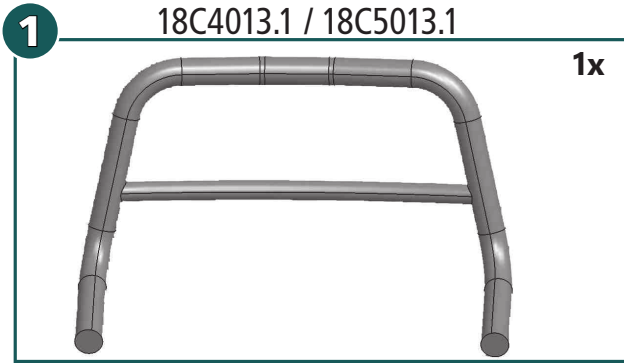
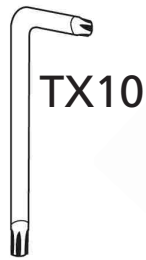
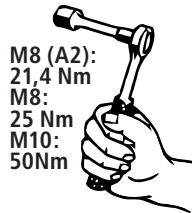
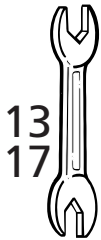

mounting kit: 18C9013

	M8x25; DIN 933 A2	2x
	M8x25; DIN 912 A2	2x
	Ø3,5 x 13; ähnl. DIN 7981B A2	2x
	M10; DIN 934 Zn	2x
	Ø 4,2; DIN 9021 A2	2x
	Ø 8,4; DIN 9021 A2	2x
	SW 13	2x

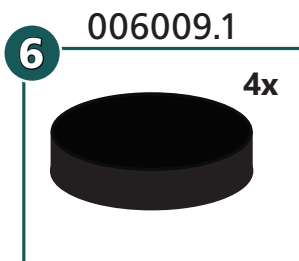
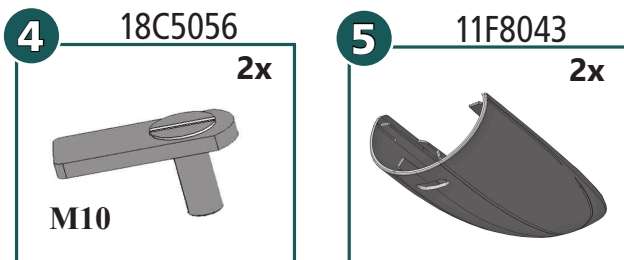
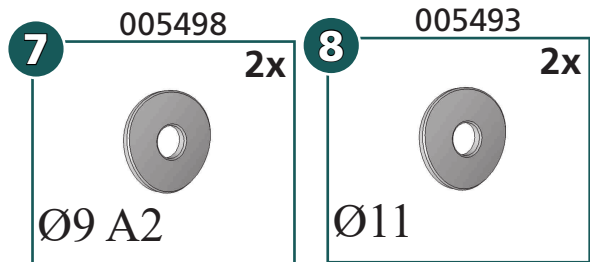
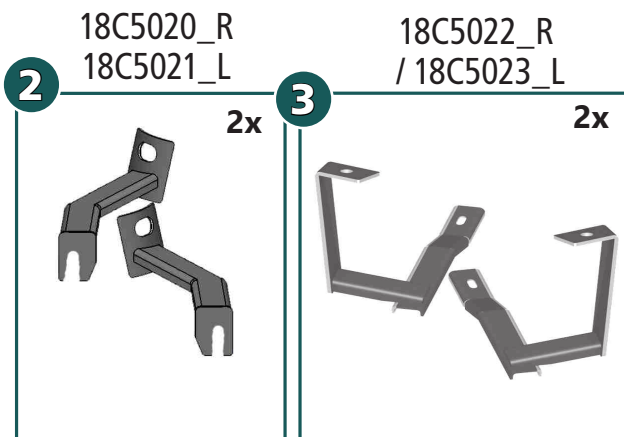

article no.:
18C4013 (S) inox
18C5013 black steel

Revision 4: 03.09.2019



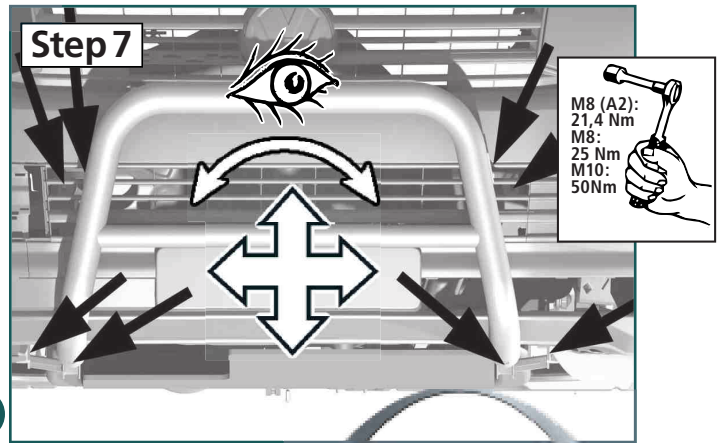
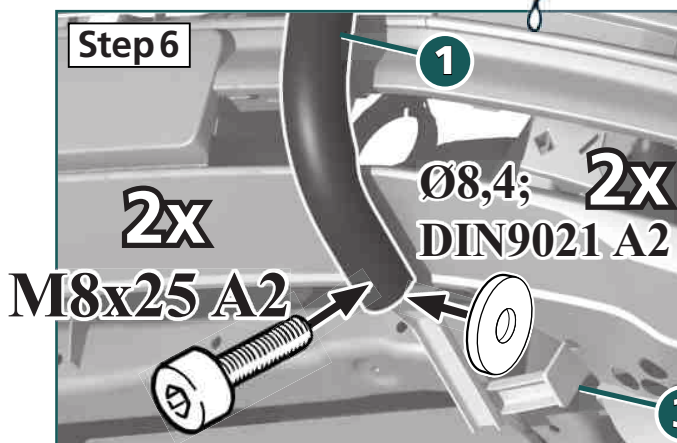
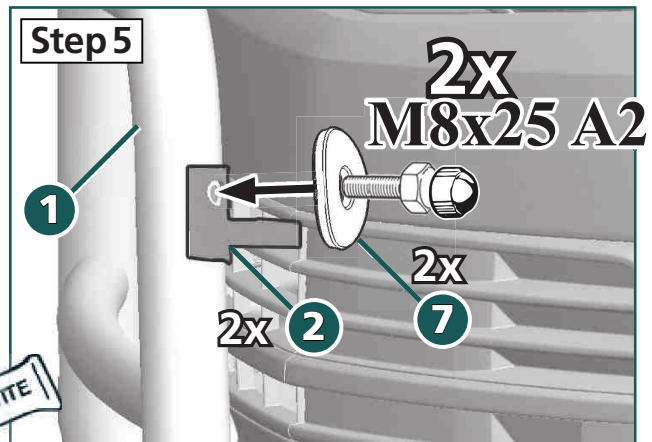
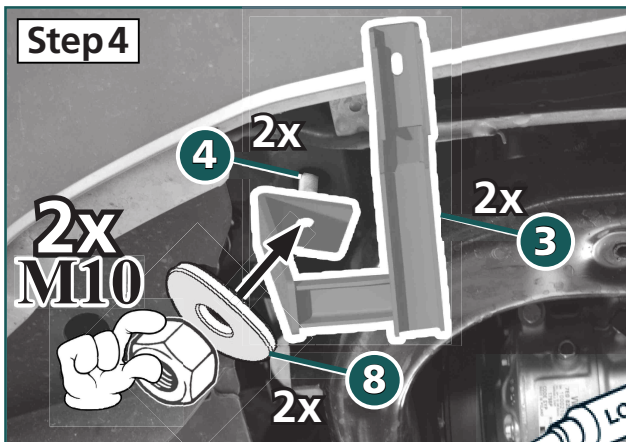
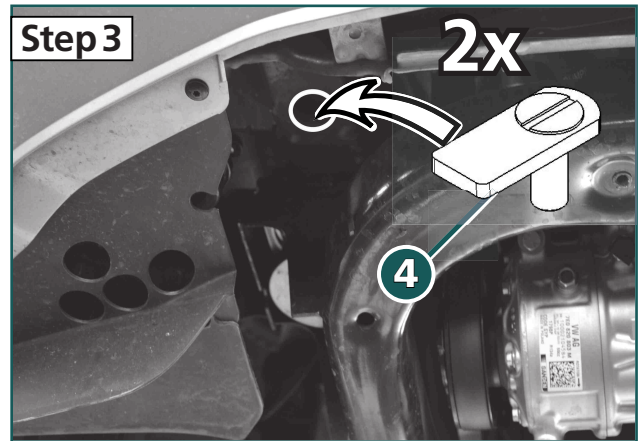
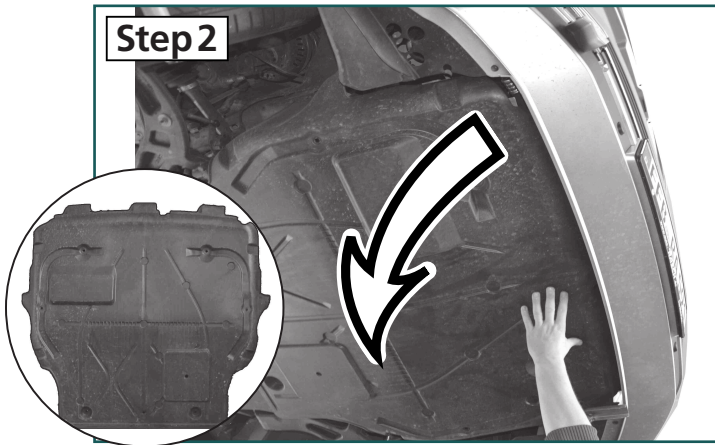
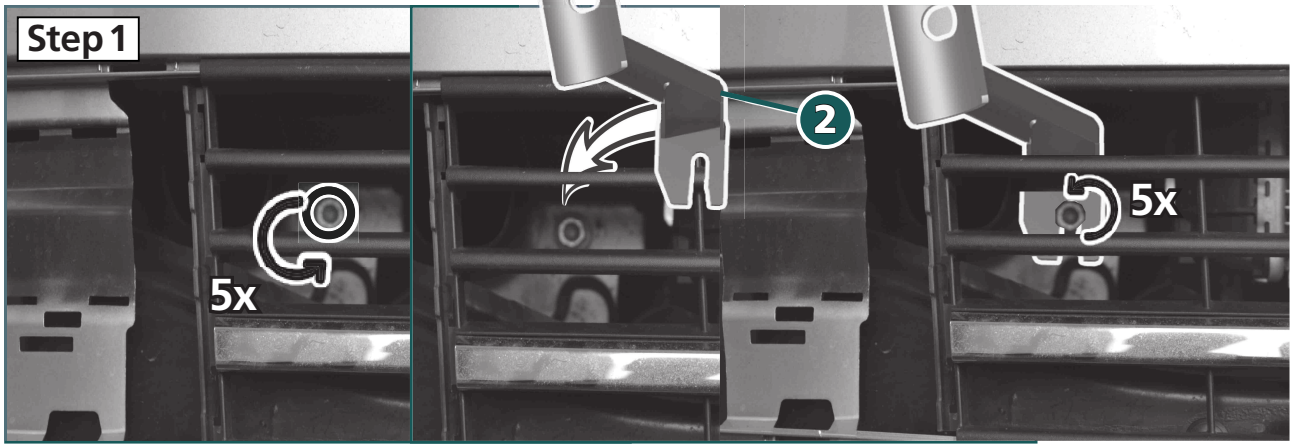

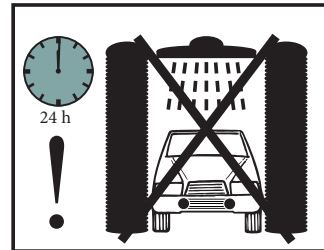
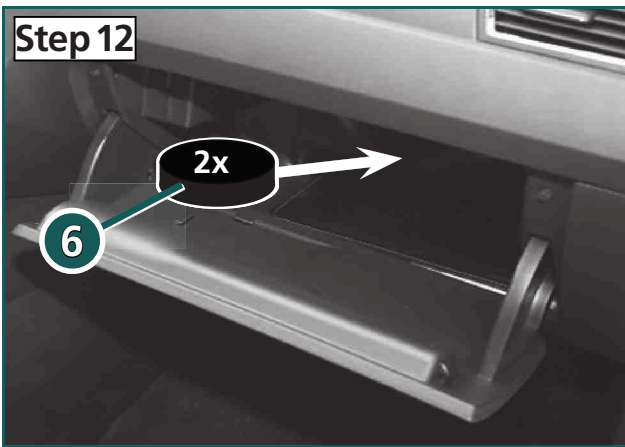
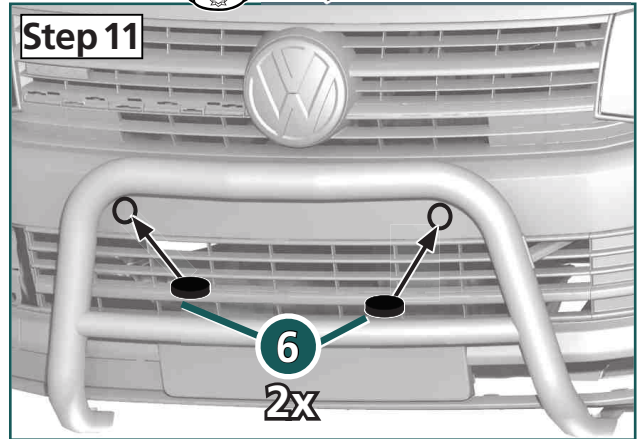
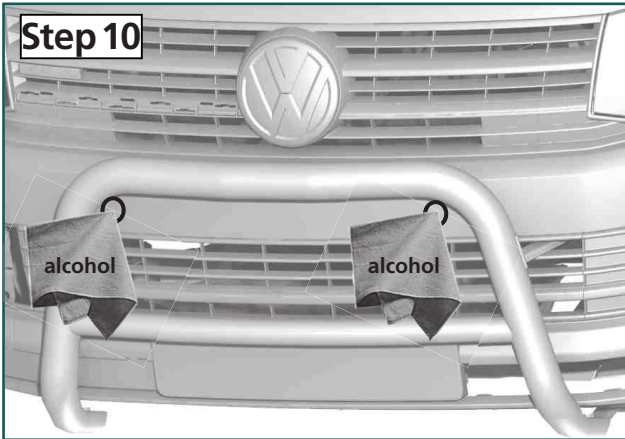
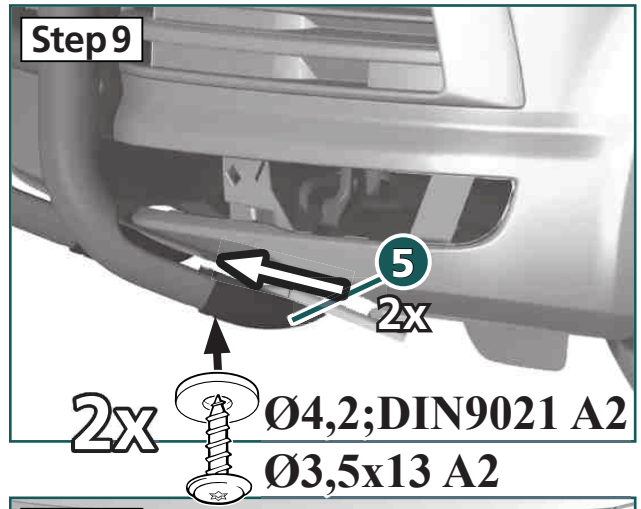
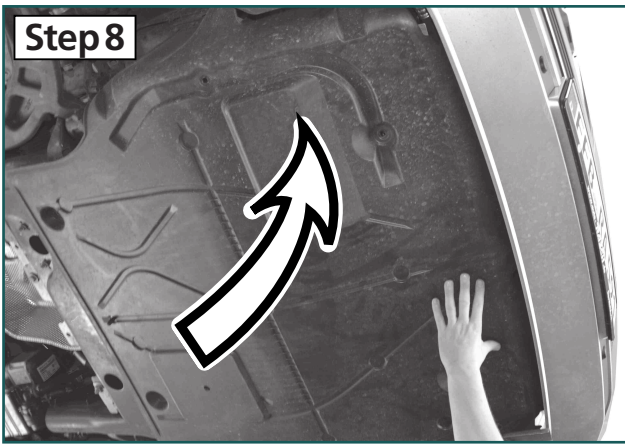

Die Funktion des PDC ist eingeschränkt
 The function of the PDC will be restricted
 La fonction de la pdc est limitée
 La función de la PDC se restringirá
 Funktio PDC on rajoitettu
 Funkce PDC bude omezeno
 Funksjonen til PDC vil være begrenset
 Funktionen för PDC kommer att begränsas

