

**18C**  
**4013N**

**VW T6, Md. 2019**

EU-pedestrian protection bar 60 mm with cross pipe 42 mm  
EU-Personenschutzbügel 60 mm mit Querrohr 42 mm  
Protection avant, homologuée CEE, 60 mm, traverse 42 mm



\*Compatible with Automatic Cruise Control /Forward Collision Mitigation  
Kompatibel mit Abstandsregeltempomat /Auffahrvermeidungs-oder warnsystem  
compatible avec radar de régulation de distance/ freinage autonome d'urgence

# ASSEMBLY INSTRUCTION

Montageanleitung • Instructions de montage

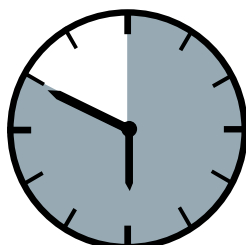

**50 Minuten**

article no.:

18C4013N (S) inox

18C5013N black steel

Revision 2: 06.02.2020



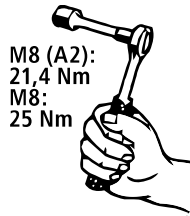
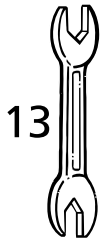

M8 (A2):  
21,4 Nm  
M8:  
25 Nm

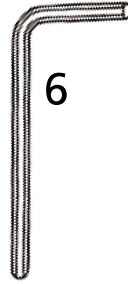
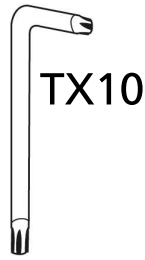

mounting kit: 18C9013N

	M8x25; DIN 933 A2	2x
	M8x25; DIN 933	2x
	M8x20; DIN 933	2x
	M8x16; DIN 933	4x
	M8x16; DIN 912 A2	4x
	Ø3,5 x 13; ähnl. DIN 7981B A2	2x
	Ø8,4; DIN 9021	2x
	Ø 4,2; DIN 9021 A2	2x
	Ø 8,4; DIN 125 A2	4x
	Ø 8,4; DIN 125 Zn	4x

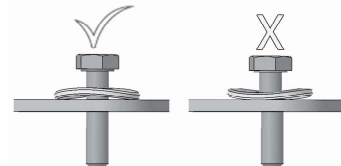
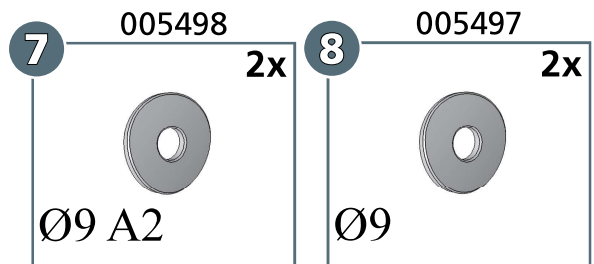
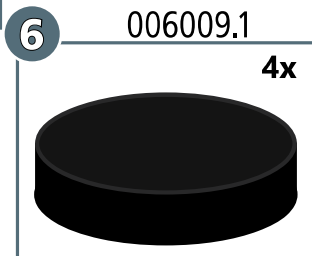
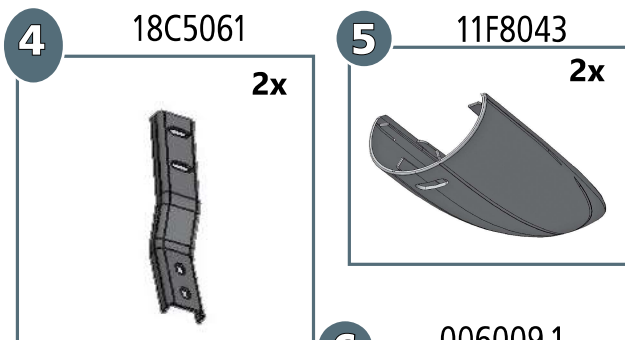
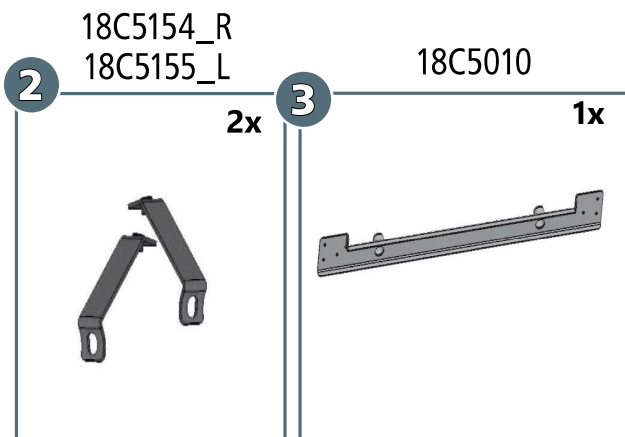

article no.:  
18C4013N (S) inox  
18C5013N black steel

Revision 2: 06.02.2020



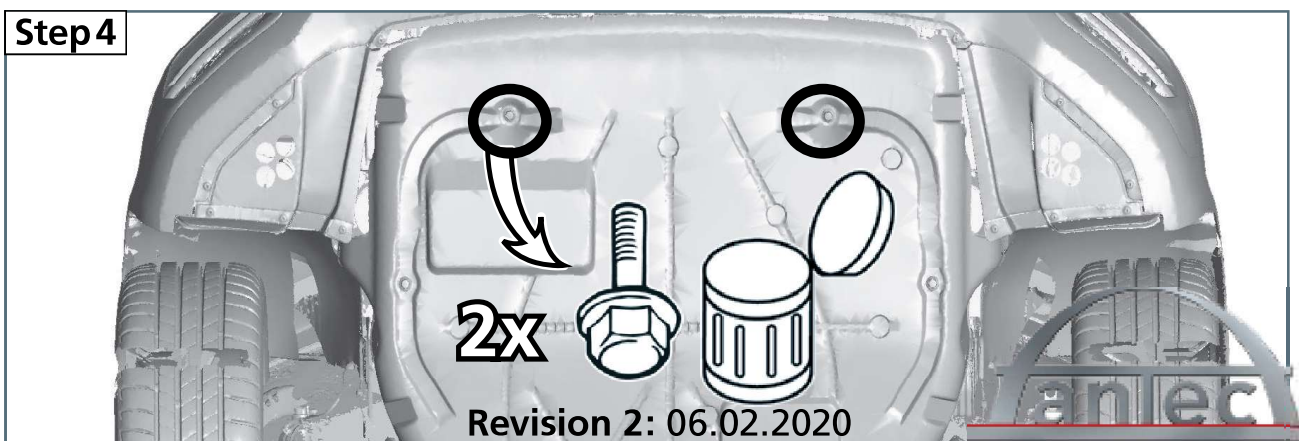
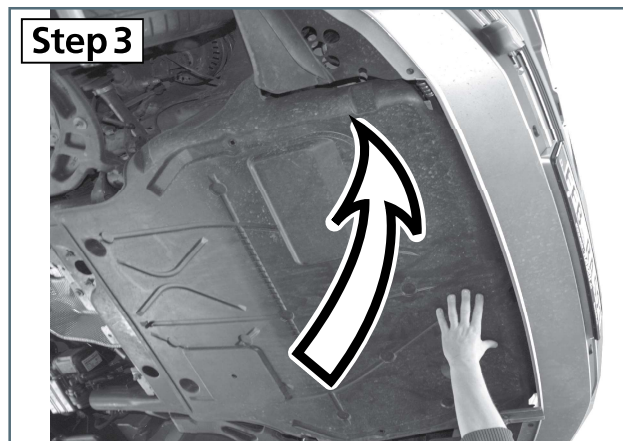
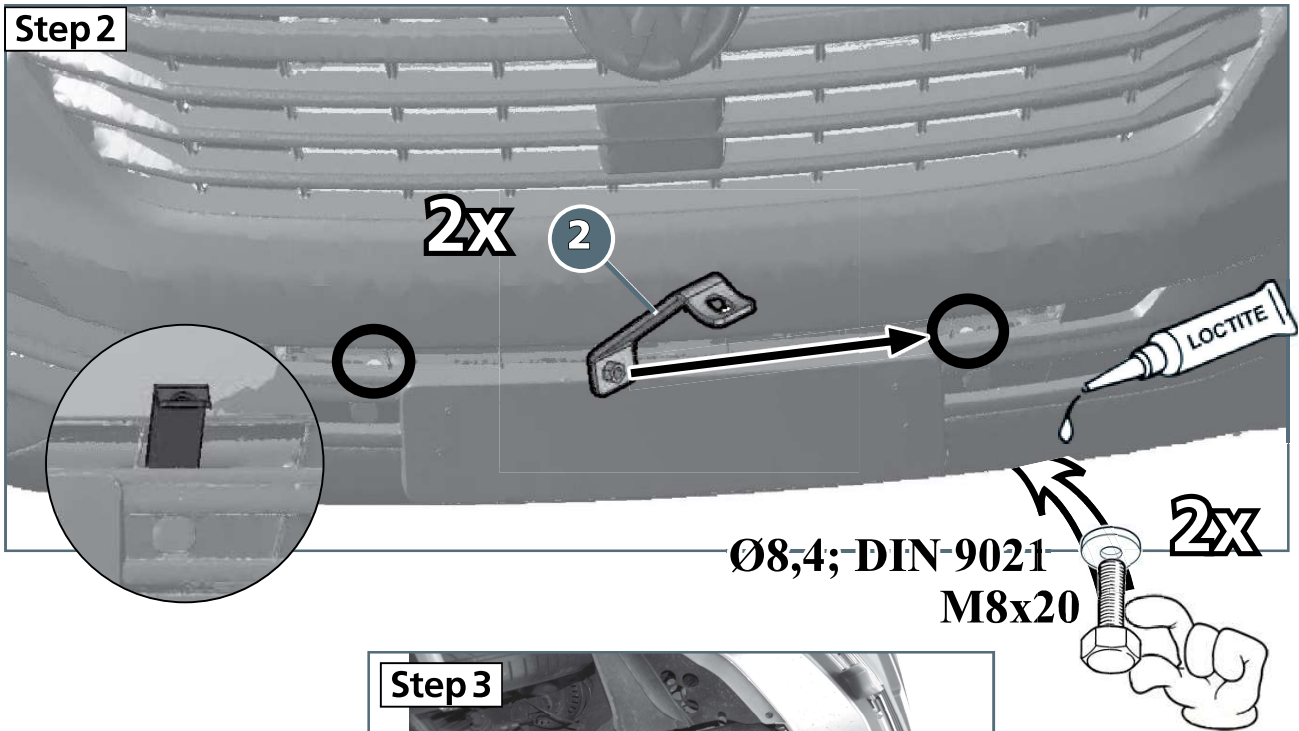
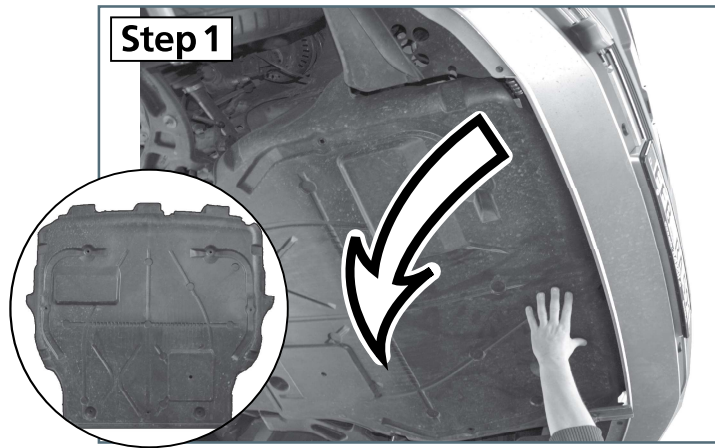

Step 5

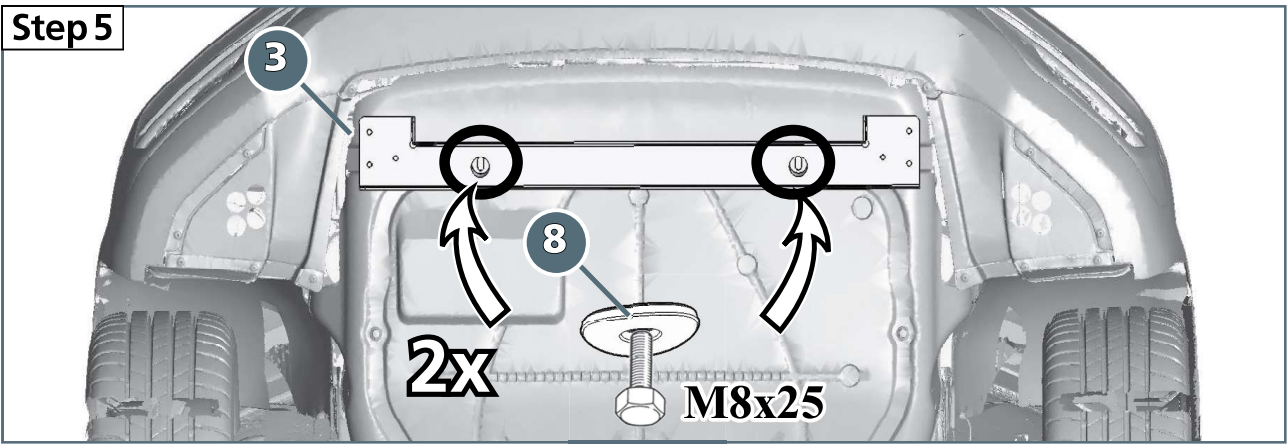

Step 6

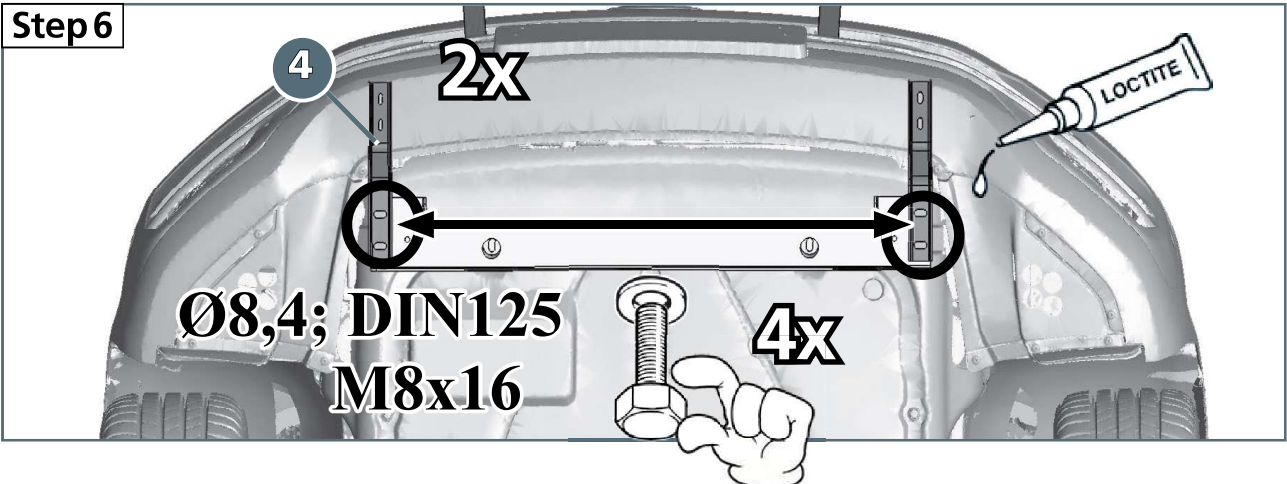

Step 7

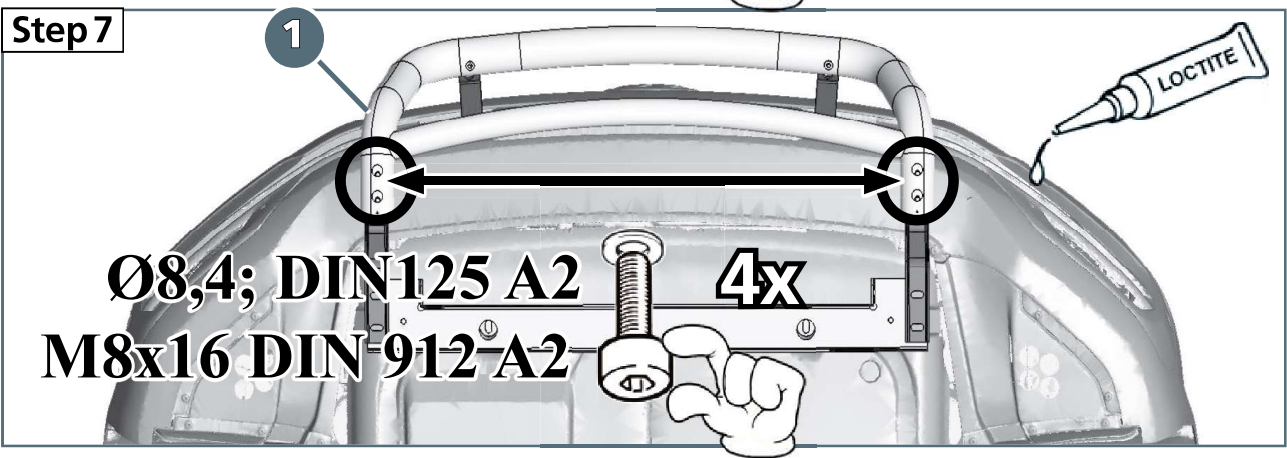

Step 8

