

**FORD RANGER 2015** 







**NOTES:**

- Ensure that both left and right hand Fender Flares suit the profile of the vehicle.  
Note the areas where the Fender Flares come in contact with the vehicle.
- Before fitting Fender Flares remove any mouldings, strips or existing flares from the wheel arch. If there is a body side moulding, mark where the moulding is to be cut, alternatively the Fender Flares can be cut to go around the moulding. Be sure to allow enough room for the extrusion.
- Read instructions carefully. This product must be installed exactly as specified in these instructions.  
Failure to do so may result in improper fit and/or retention.

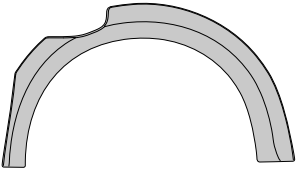
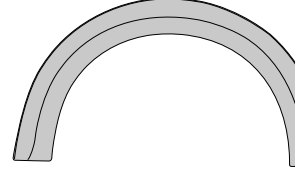
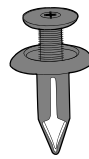
**TOOLS REQUIRED**

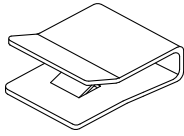
- Mild Soapy Water & Clean Cloths.
- Steel Ruler.
- Scissors or Sharp Knife.
- Phillips head Screwdriver.
- Drill and 6mm Drill Bit.
- Masking Tape.
- Non Permanent Marker / Metal Scribe.

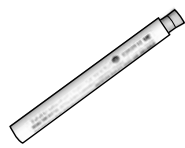
**COMPONENTS LIST**

<p><b>A</b></p>  <p>LHS x1</p>	<p><b>B</b></p>  <p>RHS x1</p>	<p><b>C</b></p>  <p>x16</p>	<p><b>D</b></p>  <p>x5m</p>
<p><b>E</b></p>  <p>x2</p>	<p><b>F</b></p>  <p>x2</p>	<p><b>G</b></p>  <p>x2</p>	<p><b>H</b></p>  <p>x1</p>

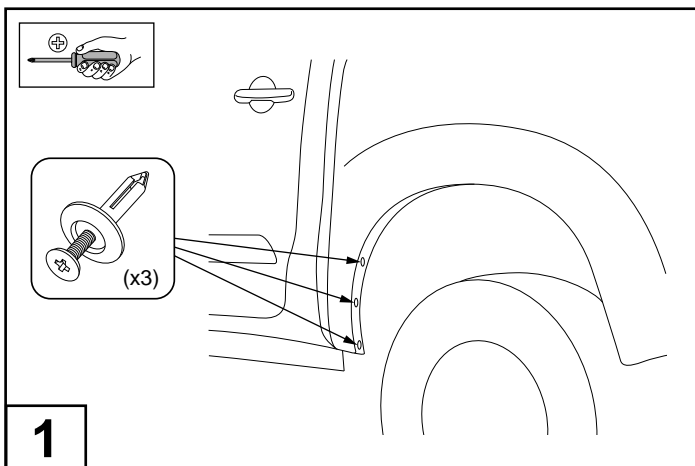

**1**  
Remove the (3) screws from inside the rear wheel arch as shown.  
NOTE: Replacement scrivets are supplied, if any scrivets are damaged upon removing from the vehicle.

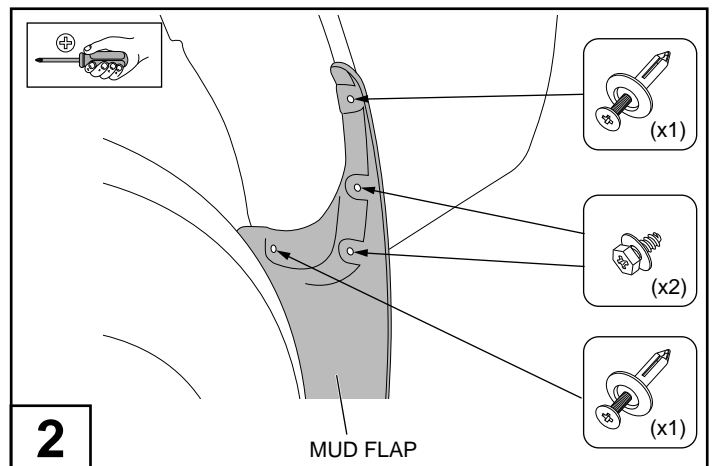

**2**  
Remove the rear mud flaps by removing and retaining the (2) screws and (2) scrivets from inside the wheel arch as shown.

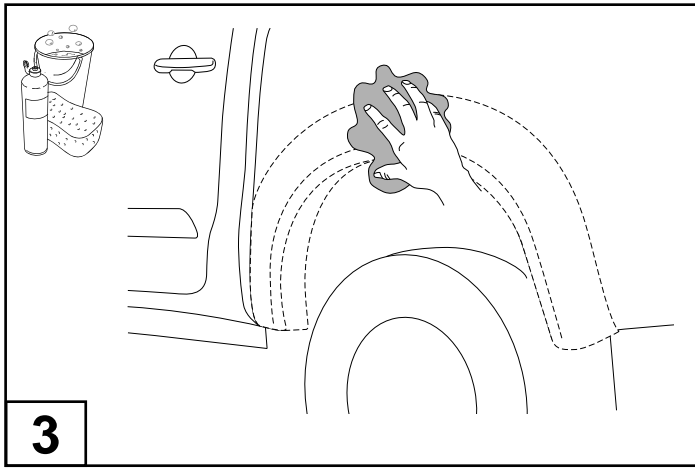

**3**

Wash the areas of contact on the vehicle and wipe dry both the vehicle and the Fender Flares with a clean cloth. Ensure inside of Fender Flares where extrusion is attached is clean.

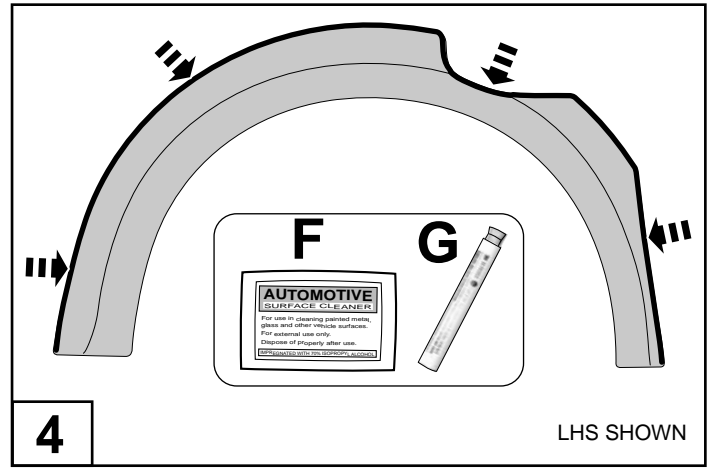

**4**

LHS SHOWN

Clean the inside edge of each fender flare where the rubber extrusion will adhere with the Alcohol wipe and prime with the Primer Stick supplied.

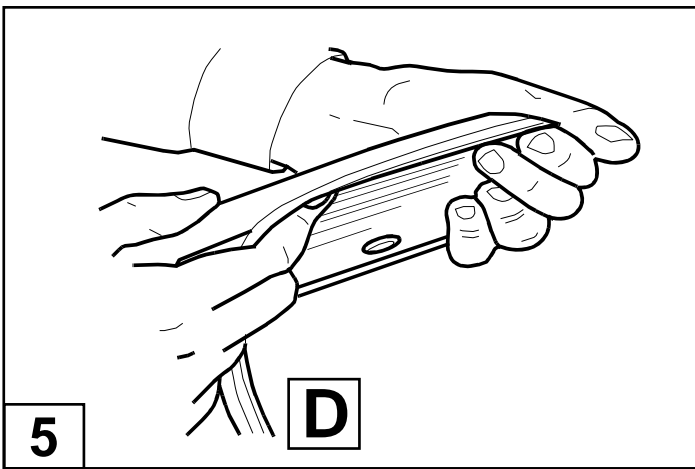

**5**

**D**

Remove approximately 50mm of the protective liner from the extrusion. Fit the extrusion to the Fender Flare along the edge that comes in contact with the vehicle's body panel.

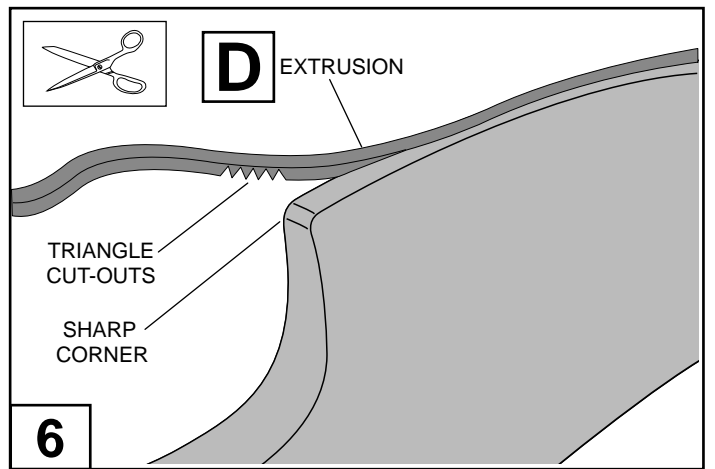

**6**

To fit the extrusion around sharp corners, cut a multiple triangles out of the extrusion where it meets the sharp corners as shown in steps 7 and 8.

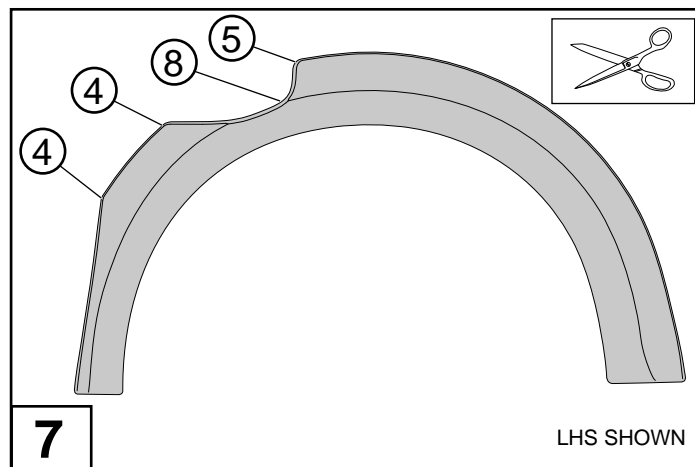

**7**

LHS SHOWN

Cut a multiple triangles out of the extrusion where it meets the sharp corners as shown on the rear right flare. Note: Numbers of cut-outs indicated in circles.

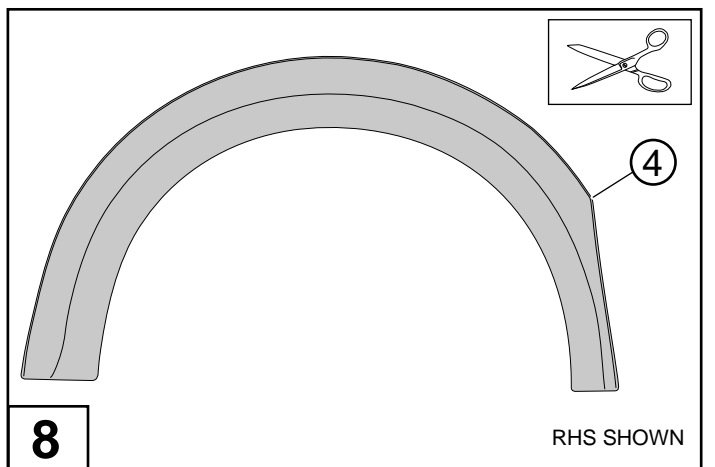

**8**

RHS SHOWN

Cut a multiple triangles out of the extrusion where it meets the sharp corners as shown on the rear left flare. Note: Numbers of cut-outs indicated in circles.

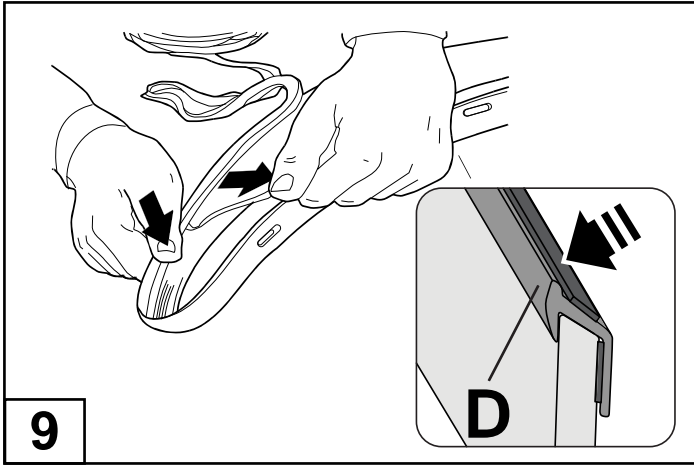

**9** Pulling at right angles to the extrusion, remove the liner from the extrusion in small portions and apply thumb pressure to ensure that it adheres to the Fender Flares. Trim any unnecessary extrusion and discard.

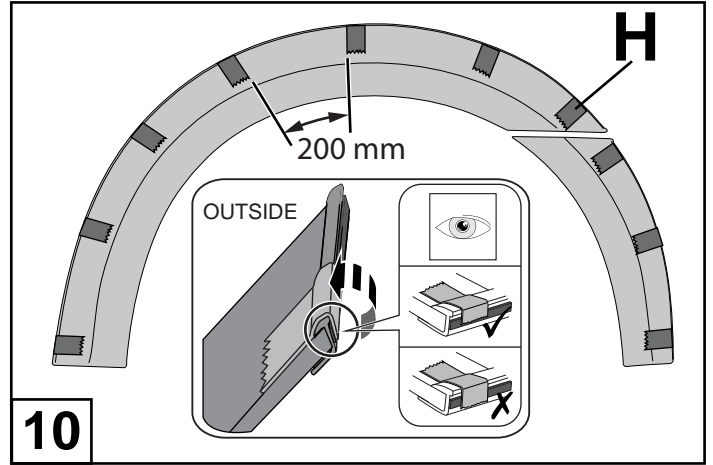

**10** Apply masking tape as shown at 200mm intervals or where required to the fender flare extrusion. Fix the tape to the rear of the extrusion over the tape lining and over the front face of the Fender Flare. Ensure the tape does not overlap the tape lining and is not fixed to the inside surface of the fender flare.

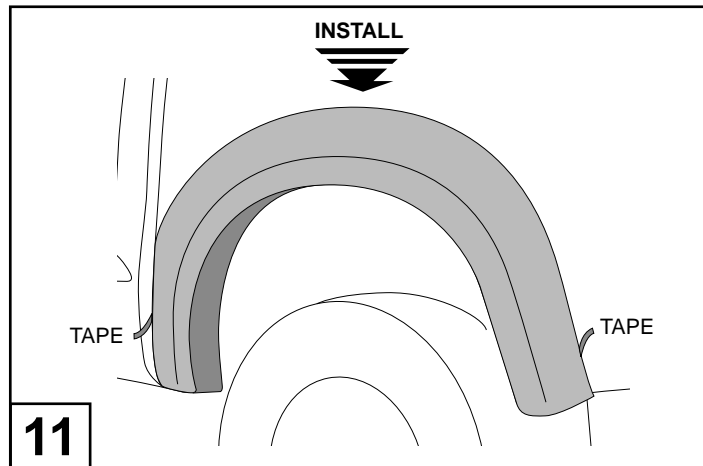

**11** Peel back red tape liner, about 50mm from each corner of the adhesive tape on the back of the fender flare. Fit the flare to the vehicle as shown.

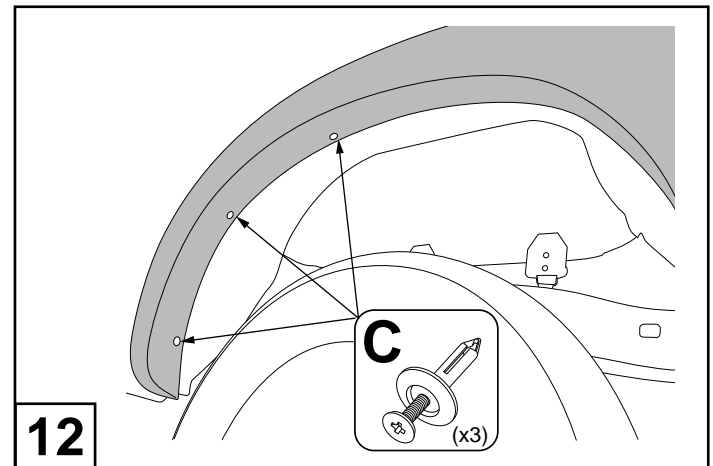

**12** Attach the front part of the rear fender flare with 3 scrivets as shown

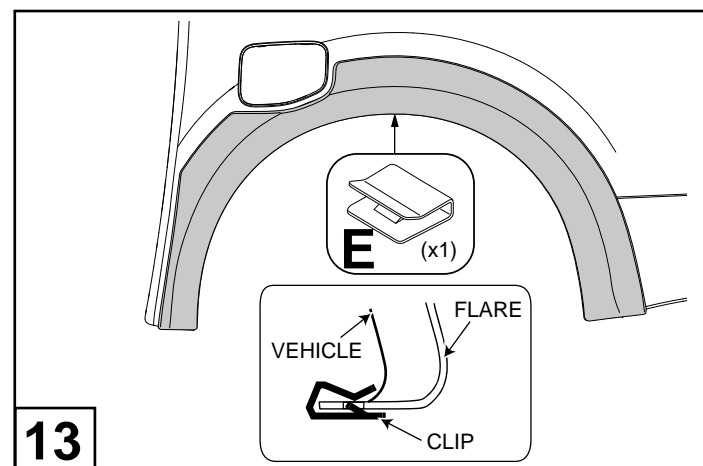

**13** Secure the middle of the fender flare to the wheel arch using 1 small metal clip as shown.

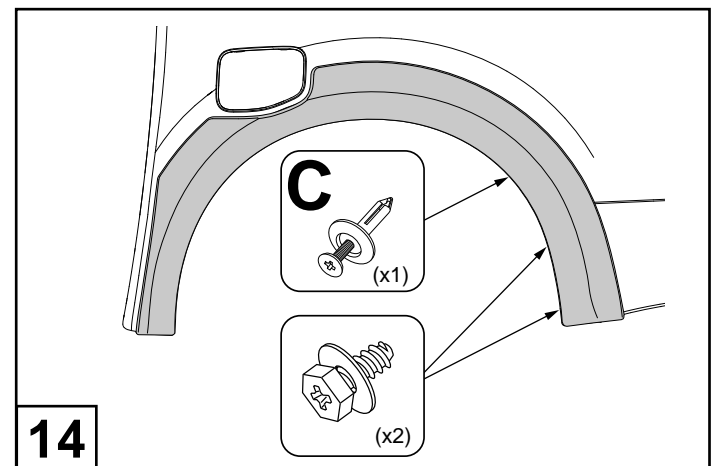

**14** Secure the rear of the fender flare to the wheel arch using 1 scrivet and 2 screws as shown.

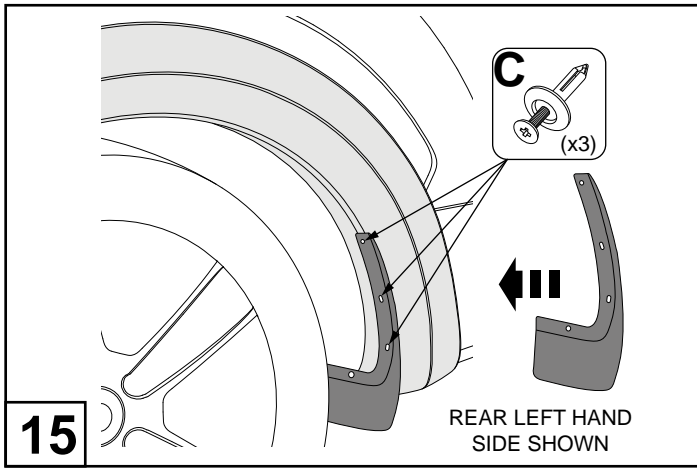

**15**

REAR LEFT HAND  
SIDE SHOWN

Fit the Mud Flaps to the Fender Flare and secure each Mud Flap with three (3) Scrivets supplied as shown.

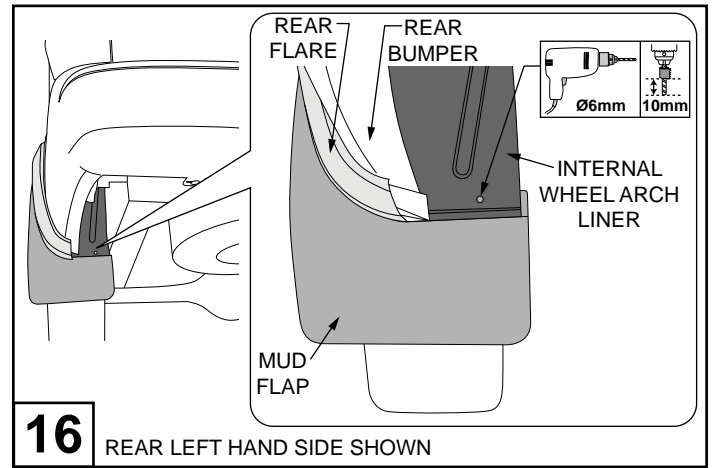

**16**

REAR LEFT HAND SIDE SHOWN

From the rear of the vehicle, clamp the Rear Mud Flap & (plastic) Internal Wheel Arch Liner. Using the hole in the Internal Wheel Arch Liner as a guide drill a  $\varnothing 6\text{mm}$  hole through the Mud Flap as shown. Take care not to contact the tyres, use a 10mm drill stop.

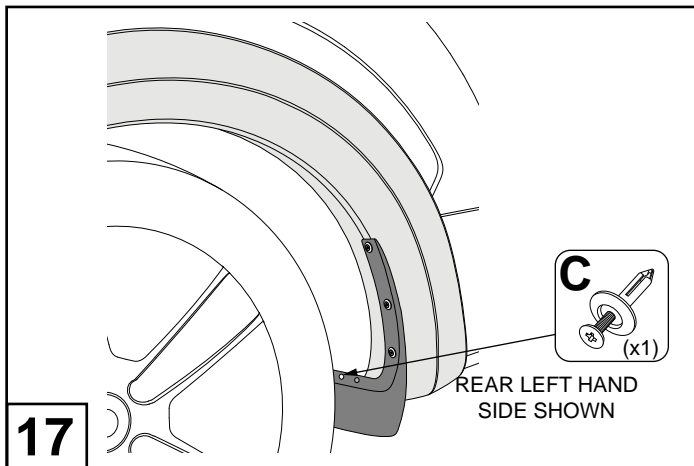

**17**

REAR LEFT HAND  
SIDE SHOWN

Fit one (1) Scrivet into previously drilled hole as shown.

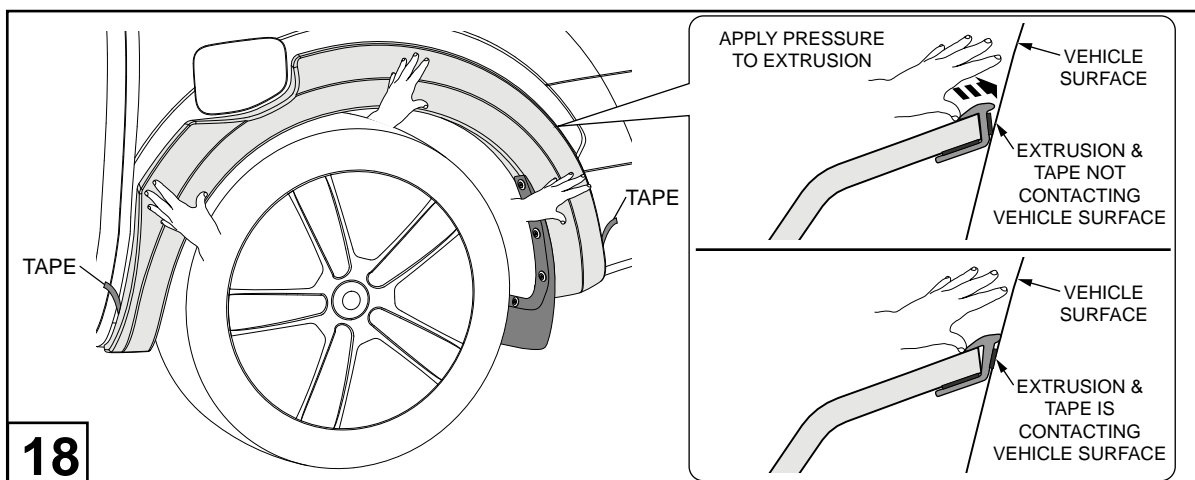

**18**

Ensure that flares are aligned. Remove the tape liner. Using your thumb and/or fingers apply firm pressure on the extrusion to ensure the extrusion and the tape is contacting the vehicle surface around the full perimeter of the flares.