

# 15V 9213R

## Ford Ranger Raptor; Md. 2019

mounting kit for 15V4213 / 15V4313

Montagesatz für 15V4213 / 15V4313

Kit de montage pour 15V4213 / 15V4313

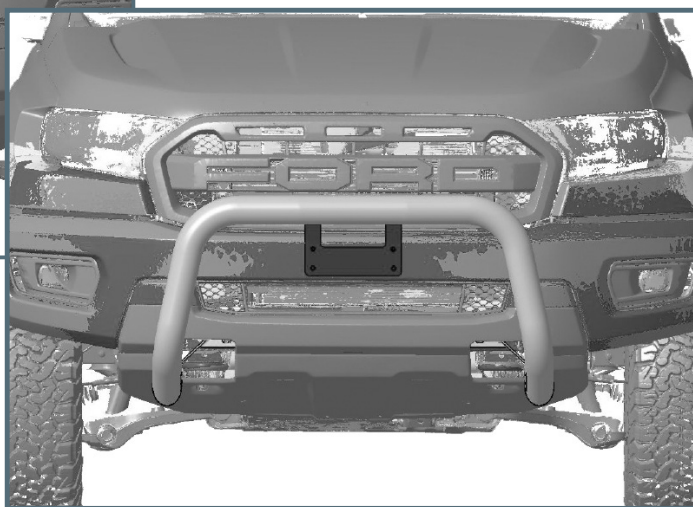
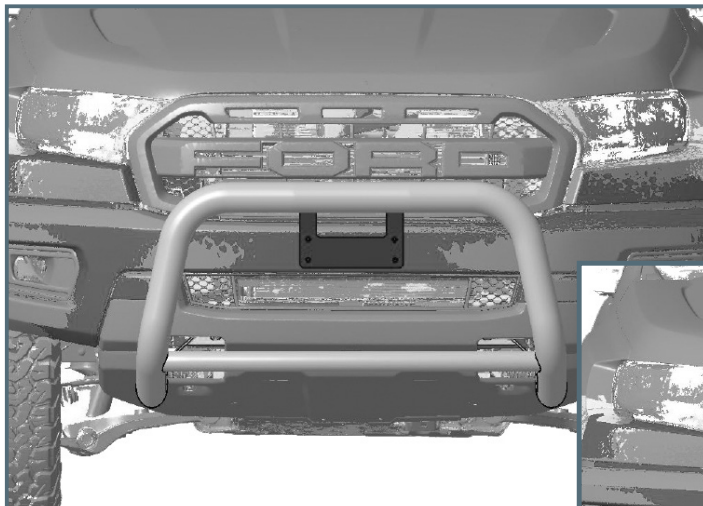

# ASSEMBLY INSTRUCTION

Montageanleitung • Instructions de montage

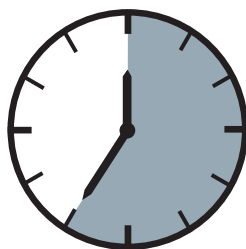

35 Minuten

article no.:  
15V9213R

Revision 2: 29.11.2023



M6:  
10 Nm  
M8(A2):  
21,4 Nm  
M6:  
2 Nm



4  
5



Ø 12,5

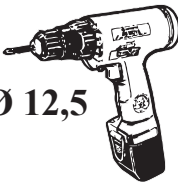

13



15V4213.1/15V5213.1

1

15V4313.1/15V5313.1

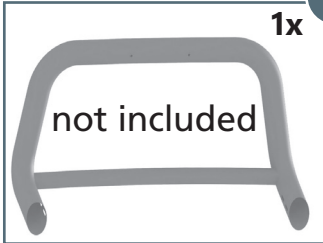

1x

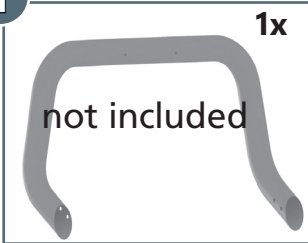

1x

mounting kit: 15V9213R

	M6 x 25; DIN 7991 Zn	4x
	M8 x 25; ähnl. ISO 7380 Zn	4x
	M8 x 25; DIN 933 A2	2x
	Ø 4,8 x 19 mm; DIN 7981 A2	4x
	Ø 5,3; DIN 9021 A2	4x
	SW 13	2x
	Getowell M6	2x

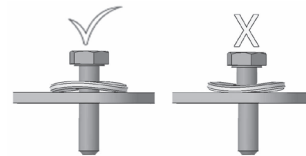
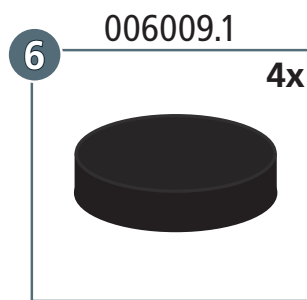
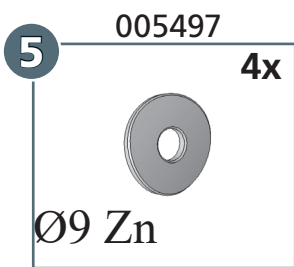
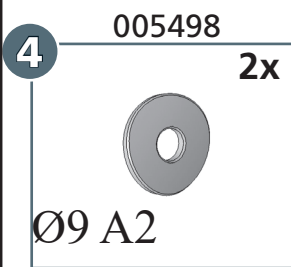
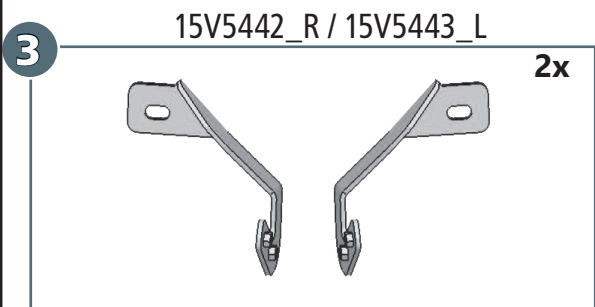
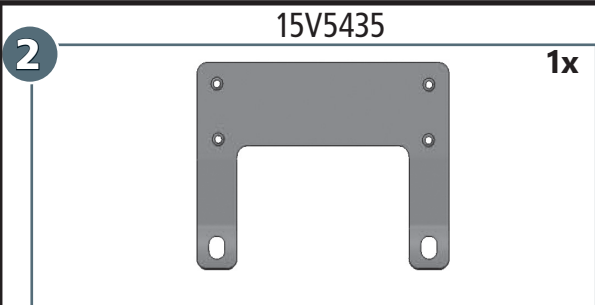

**Step 1**

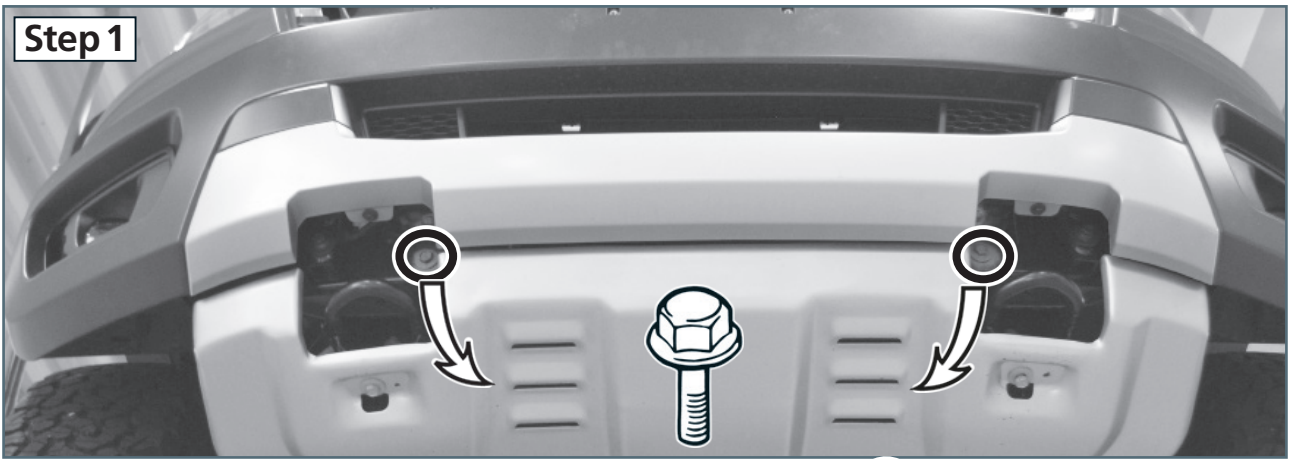

**Step 2**

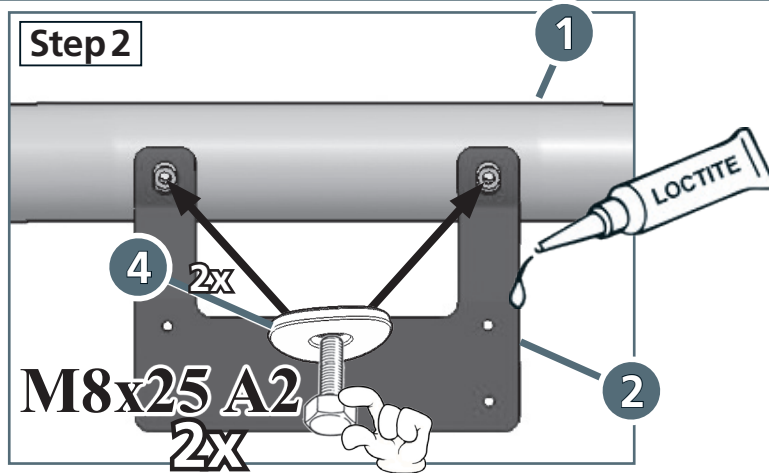

**Step 3**



**Step 4**

